

NOTE : PRIMARY DIMENSIONS ARE INCHES AND DIMENSIONS IN BRACES ARE METRIC

MODEL	DIMENSION inch {mm}										INLET/OUTLET <MALE>	INLET AIR FLOW <SCFM>	NET WEIGHT <LBS>	SHIPPING WEIGHT <LBS>
	A	B	C	D	E	F	G	H	L	W				
HG25	19.56 {497}	2.80 {71}	2.24 {57}	4.33 {110}	7.91 {201}	2.05 {52}	2.05 {52}	22.36 {568}	15.51 {394}	14.48 {368}	NPT 3/4"	25	66	88
HG35												35		

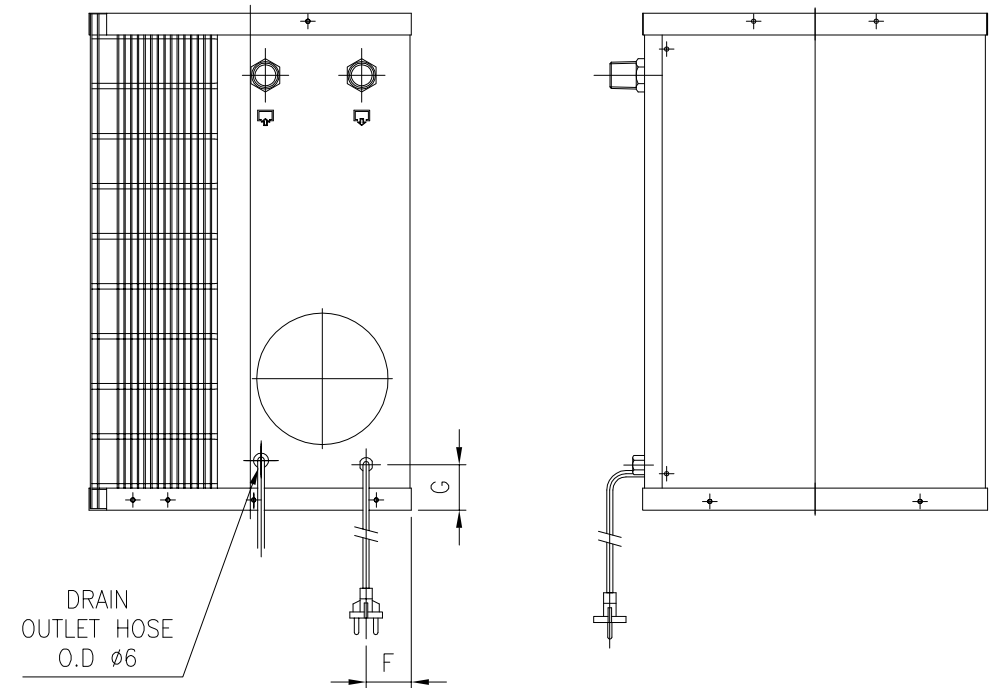
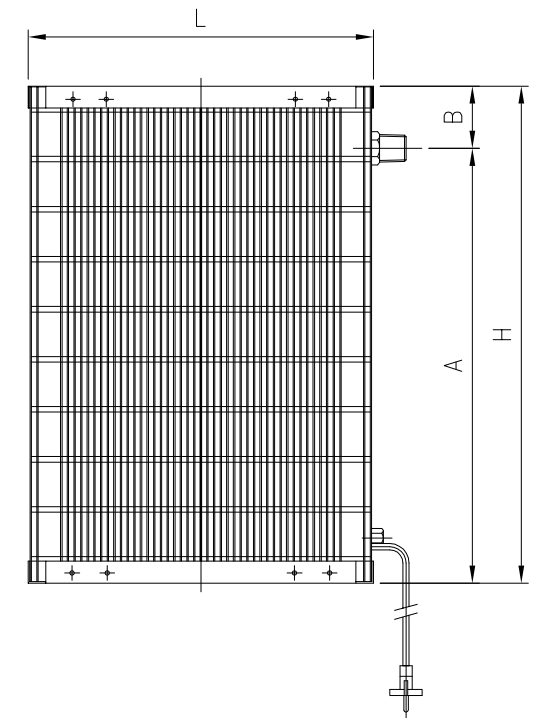
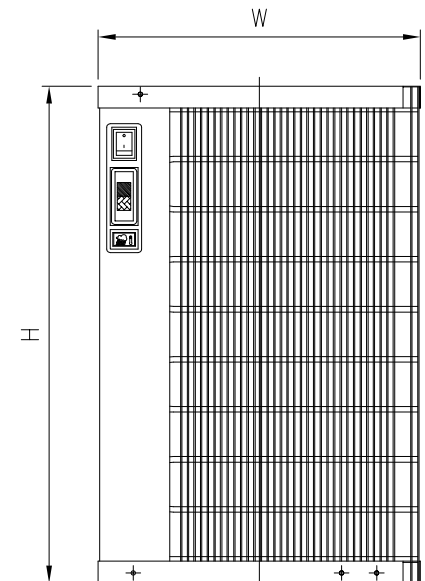
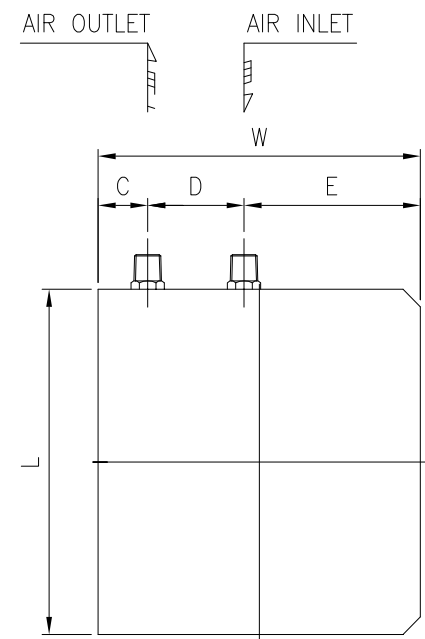

SERVICE :  
COMPRESSED AIR

OPERATING CONDITIONS :

RATED INLET AIR PRESSURE - 100 PSIG  
 MAXIMUM INLET AIR PRESSURE - 250 PSIG  
 MINIMUM INLET AIR PRESSURE - 30 PSIG  
 RATED INLET AIR TEMPERATURE - 100 °F  
 MAXIMUM INLET AIR TEMPERATURE - 120 °F  
 MINIMUM INLET AIR TEMPERATURE - 40 °F  
 RATED AMBIENT AIR TEMPERATURE - 100 °F  
 MAXIMUM AMBIENT AIR TEMPERATURE - 120 °F  
 MINIMUM AMBIENT AIR TEMPERATURE - 40 °F

SPECIFICATIONS :

ELECTRICALS - 115V/1PH/60Hz   
 REFRIGERANT - HFC-134a (R-134a)  
 EXPANSION DEVICE - CONSTANT EXPANSION VALVE  
 DRAIN TYPE - ELECTRONIC DRAIN  
 CONDENSER TYPE - STATIC CONDENSER

REV.	DESCRIPTION	BY	DATE	APPROVED
A	ECF-130115-DDB-01	NLC	1/18/13	DDB

REVISION HISTORY ( INDICATES LATEST REVISION)

UNLESS OTHERWISE SPECIFIED  
 DIMENSIONS ARE IN INCHES  
 TOL. ON FRACTIONS: ± 1/16  
 TOL. ON DECIMALS: ± .015 (2 PLACE)  
 TOL. ON DECIMALS: ± .030 (3 PLACE)  
 TOL. ON ANGLES: ± .5

THIRD ANGLE PROJECTION

FILER NO.  
 DRAWN BY: DWC  
 DATE: 6/15/05  
 CHECKED BY: MAP  
 DATE: 6/15/05  
 APPROVED BY: JAL  
 DATE: 6/15/05

**Deltech**<sup>®</sup>

REFRIGERATED AIR DRYER (STATIC COND)  
 GENERAL ARRANGEMENT HG25-35

SIZE B	DWG. NO. GA03DEL-0017	REV. A
SCALE: NONE	EST. WT.	SHEET 1 OF 1